

OPERATION MANUAL

Flooring Cutter MD-330

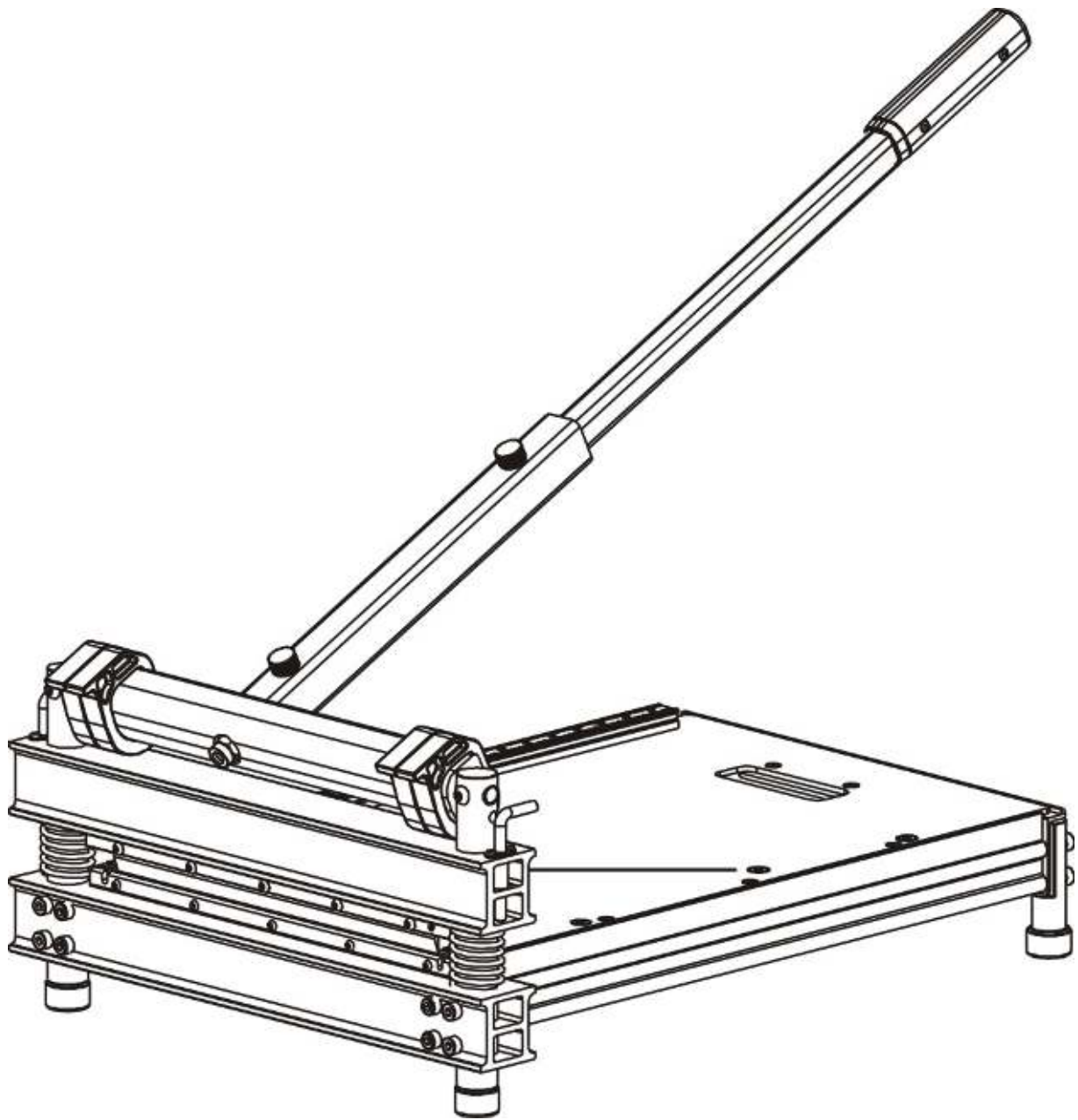



WARNING: FAILURE TO FOLLOW THESE RULES MAY RESULT IN SERIOUS INJURY! USING THIS MACHINE WITH RESPECT AND CAUTION WILL CONSIDERABLY LESSEN THE POSSIBILITY OF PERSONAL INJURY.

SAFETY RULES FOR THE FLOORING CUTTER

- 1. READ AND UNDERSTAND THIS INSTRUCTION MANUAL BEFORE OPERATING THE D-Cut MULTI-FLOORING CUTTERS.**
2. If you are not thoroughly familiar with the operation of D-Cut Multi-flooring Cutter, obtain advice from a qualified instructor or call 630-916-9100 USA
3. Stay alert. Do not operate while under the influence of drugs, alcohol, or medication.
4. Always wear safety approved eye protection with side shields(ANSI Z87.1)
5. Keep work area free of debris.
6. Keep children and unauthorized persons away from the D-Cut Multi-flooring Cutter and work area.
7. Make sure tool is secure. Operate only on a firm substrate or solid stand.
8. Use the right tool. Do not force the D-Cut Multi-flooring Cutter or use it for a job for which it was not designed; use only on approved materials.
9. Keep the blade sharp. A dull blade will not perform properly.
10. Always keep hands away from blade while operating or carrying the cutter.
11. Do not alter or misuse this tool. The D-Cut Multi-flooring Cutter is precision built; modifications not specified in this manual may result in a dangerous and unsafe environment.
12. Maintain the D-Cut Multi-flooring Cutter with care. Keep Blade sharp and clean. Follow instructions for changing accessories.
13. Use only recommended accessories. The use of improper accessories may be hazardous and cause injuries.
14. Never leave the D-Cut Multi-flooring Cutter unattended. Secure the handle with the lock chain when not in use.

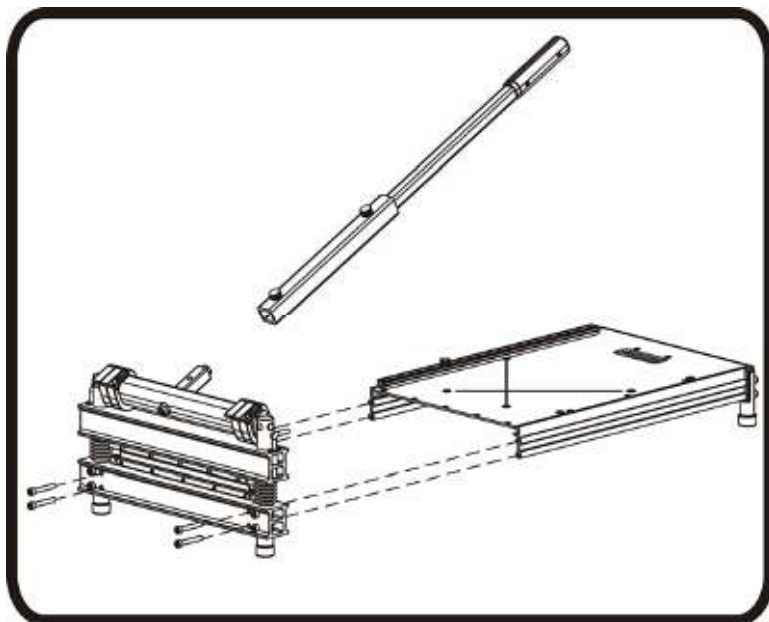

Installation Install the table to the cutter base with provided screws and bolts as shown. Then insert the handle into the handle base as show and tighten provided screw.

Warning: Do not put your fingers against the sharp edge of the blade at any time.

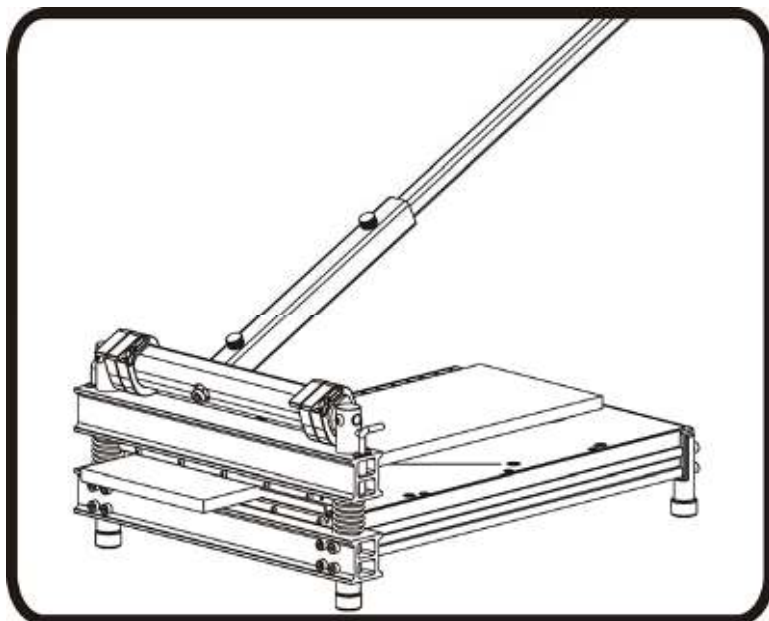

Straight Cutting

Insert material between the cutting blade and the base, flush it with the guide bar as shown and hold the material then push handle down to complete a cut.

Warning: Maintain control of the handle. Do not allow handle to slam back after making a cut.

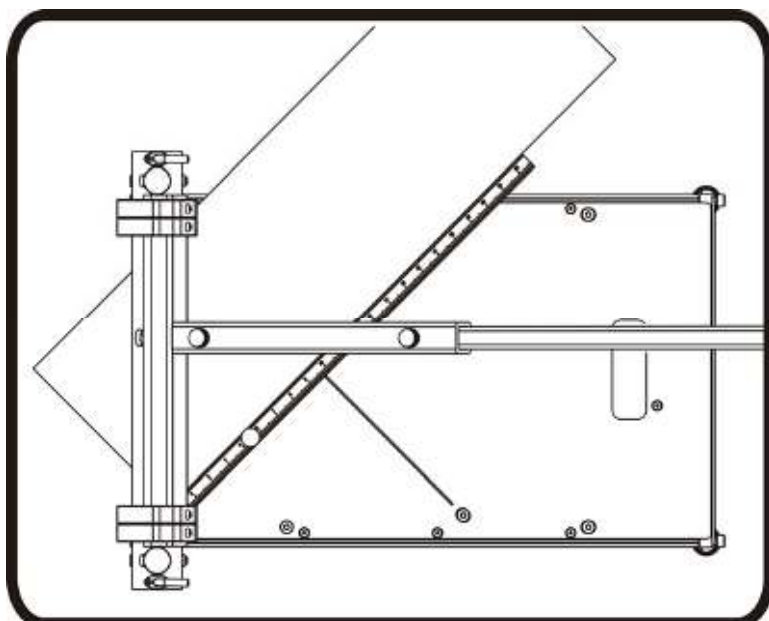

45° Cutting

Adjust the angle attachment to 45°. Insert material between the cutting blade and the base, against the angle attachment as shown, then push the handle down to complete a cut.

Warning: Maintain control of the handle. Do not allow handle to slam back after making a cut.



Changing the Blade

Use the provided Allan wrench to remove the five screws, then hold the blade by each end and carefully move the blade out of blade holder.

Note: the flat side of the blade facing the table.

Warning: Do not put your fingers against the sharp edge of the blade at any time.

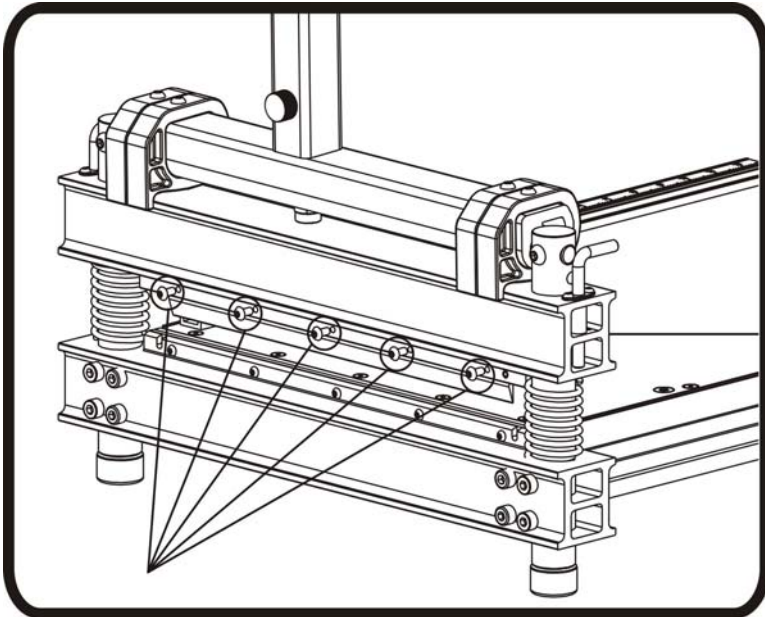

Changing the Nylon Bar

Use the provided Allan wrench to remove the five screws, then hold the nylon bar and carefully move it out of nylon bar holder.

Warning: Do not put your fingers against the sharp edge of the blade at any time.

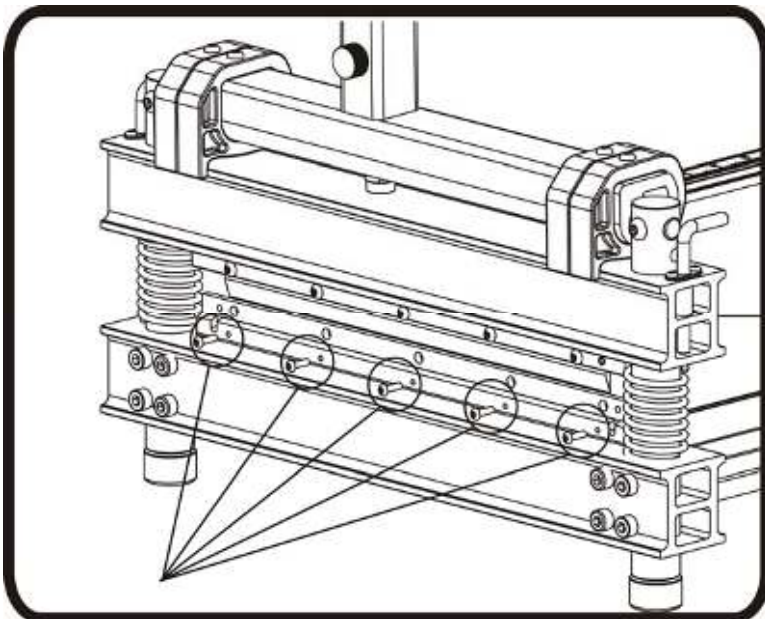

Transport

Insert the pin as shown to the hole in the aluminum eccentric cam and carry the cutter as shown.

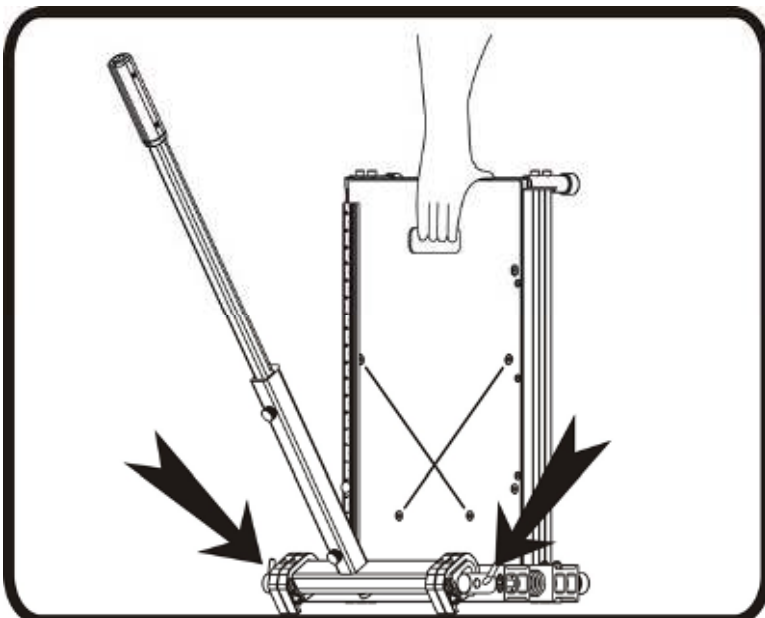

PARTS LIST

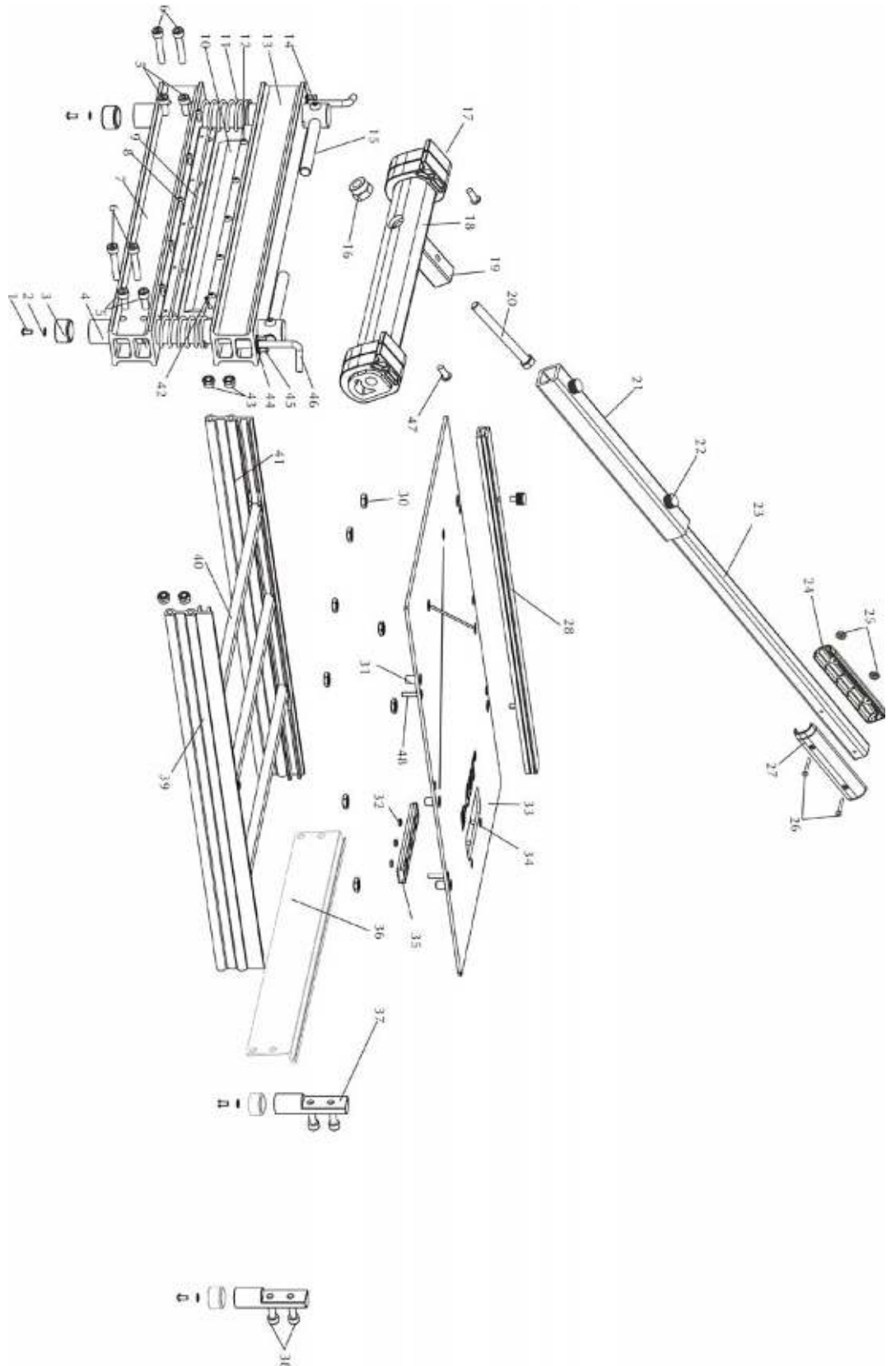



PARTS LIST

	Parts	Q'ty		Parts	Q'ty
1	Screw M6 × 12	4	25	Nut M4	2
2	Washer Ø6	4	26	Bolt M4 × 30	2
3	Rubber Feet	4	27	Left ABS Handle	1
4	Rod	2	28	Guide Bar	1
5	Hex Bolt M8 × 55	4	30	Nut M10	8
6	Hex Bolt M8 × 50	4	31	Sleeve	6
7	Main Base	1	32	Nut M5	3
8	Screw M4 × 14	5	33	Working Table	1
9	Nylon Bar	1	34	Screw M5 × 12	3
10	Blade	1	35	Carry Handle	1
11	Spring	1	36	End Board	1
12	Screw M5 × 10	5	37	Foot	2
13	Blade Base	1	38	Bolt M8 × 30	4
14	Screw M8 × 14	2	39	Frame A	1
15	Shaft	2	40	Cross Bar	3
16	Nut M12	1	41	Frame B	1
17	Nylon Wheel	4	42	Spring Pin	1
18	Aluminum Eccentric Cam	1	43	Nut M8	4
19	Handle Base	1	44	Pin Sleeve	2
20	Bolt M12 × 120	1	45	Screw M4 × 10	4
21	Handle A	1	46	Pin	2
22	Screw M8	3	47	Screw M6 × 16	4
23	Handle B	1	48	Screw M5 × 25	6
24	Right ABS Handle	1			